

Highly Integrated GPS Receiver Overcomes Jamming, Pinpoints Location

From RF CMOS silicon-on-sapphire (SOS) technology, a monolithic low-power, radiation hardened GPS front-end — designed to overcome jamming has been developed for military/aerospace applications.

By Dan Nobbe

Hand-held GPS receivers are used by soldiers to find their way in strange lands, especially at night. GPS receivers are also used to find downed pilots and locate other strategic personnel. After the Gulf War, the U.S. Army announced it would install GPS in all armored vehicles to help minimize friendly fire incidents, which was a major source of casualties in Operation Desert Storm. Friendly fire incidents most often were caused by armored unit commanders who were lost in the featureless Iraqi desert or were out of position during ground attacks.

It is clear from these experiences that the military would like to have GPS location capability on every person, vehicle and projectile. The projectiles do not stop at cruise missiles, but also include 155 mm Howitzers and 5-inch Navy deck guns with GPS guidance. These military GPS receivers must be able to receive the military version of the spread-spectrum code, and they must be anti-jamming receivers.

The first requirement is so the military can dither or “scramble” the commercial code to prevent the enemy from using the GPS signal, but still allowing the full precision for the desired users. The second requirement, anti-jamming, surfaced in 2003, although it had been anticipated previously.

“From the day we built GPS, we’ve been working on ways to overcome jamming,” said Lt. Col. John Carter, chief of space

requirements at the Pentagon. “We’re very confident we can do that.” (Master Sgt. Scott Elliott for Air Force News, Feb 21, 2003) GPS jammers can be detected, located, and destroyed. Upgrades to the GPS system are planned to improve their performance.

Despite the system improvements and the ability to find and remove jammers, military and even industrial GPS systems must be designed to handle jamming, whether intentional or unintentional. Anti-jam capability comes about through smart antennas and high dynamic range receivers. Peregrine Semiconductor has created a highly integrated dual-band anti-jam GPS receiver for these applications. Additionally, due to radiation-hard-

ened properties of Peregrine’s Ultra Thin Silicon (UTSi) process, this GPS receiver technology can be extended to spacecraft also.

GPS Overview

Global Positioning Satellite (GPS) was researched in the 1960s and was officially established as a program in 1969. It started as a Department of Defense program and the Air Force now has operational responsibilities.

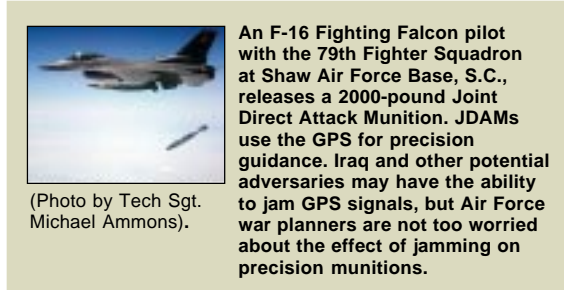

(Photo by Tech Sgt. Michael Ammons).



Figure 1. NAVSTAR GPS satellite. Photo courtesy NASA

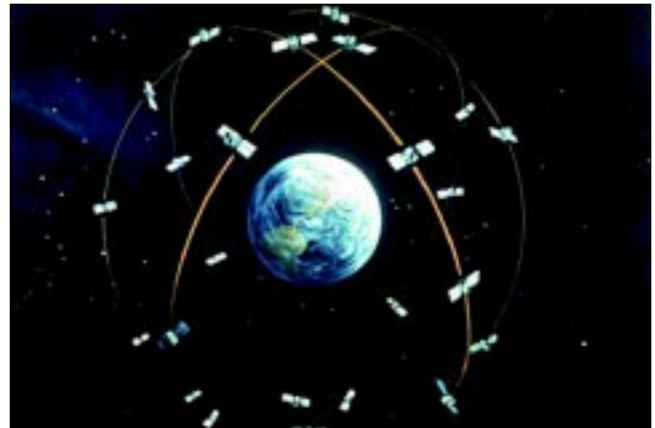

Figure 2. Artist’s concept of the GPS satellite constellation. Photo courtesy U.S. Department of Defense

Table 1. Specified Terrestrial GPS Signal Strength		
Specified RX signal levels	Min (dBm)	Max (dBm)
L1, P(Y)	-133	-125.5
L1, C/A	-130	-123
L2, P(Y)	-136	-128
L2, C/A	-136	-128

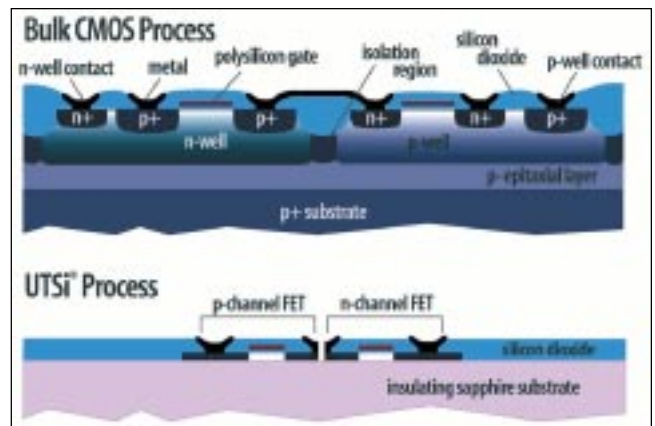

Figure 3. Cross Section of Bulk CMOS and UTSi CMOS Devices

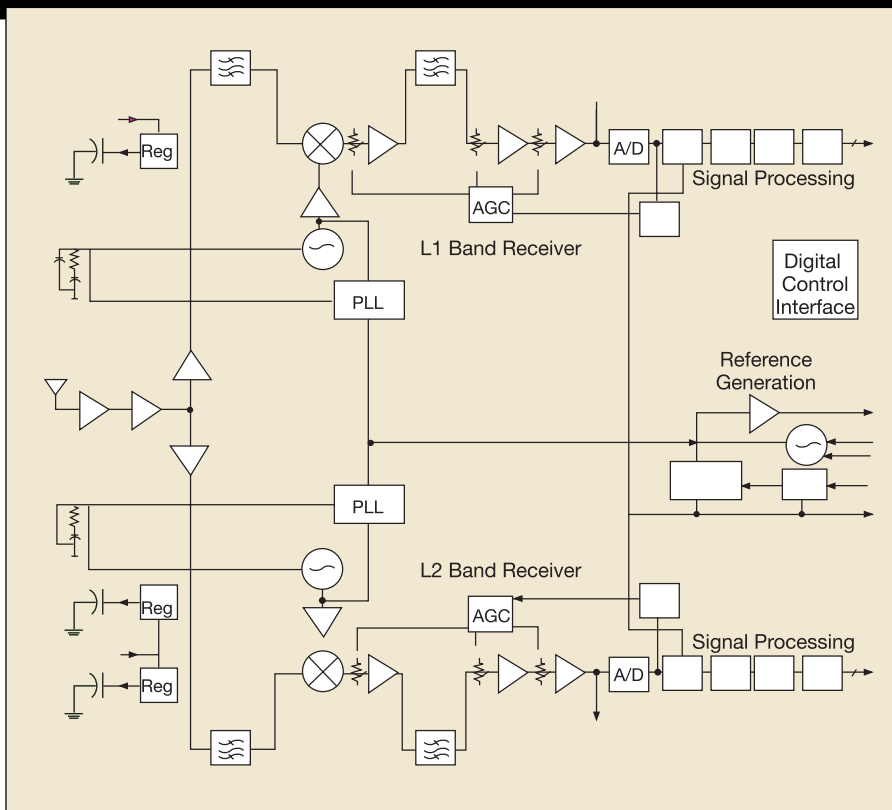

Figure 4. Block Diagram of Integrated Anti-Jam Dual Band GPS Receiver

their orbits every 12 hours as shown in Fig.1.

The GPS constellation shown in Fig.2, essentially a set of man-made stars, is placed into six orbital planes, with four satellites per plane. Initial operational capability with 24 satellites was established in December 1993

and the full operational capability was met in April 1995. Currently 29 NAVSTAR GPS satellites are in orbit, with launch dates from February 1989 to December 2003. The system is designed so that at least five satellites are visible at any point on the earth's surface

(with a clear view of the sky). The constellation is constantly being replaced and upgraded.

The location of the satellites is precisely known at all times, and a GPS user determines their position from synchronized signals transmitted by the satellites. After adjusting for various complexities such as Doppler shift, etc., the user position is calculated by triangulation using the known satellite locations. Classical geometry requires ranges (times) to only three points (satellites) to uniquely define position. However, a fourth satellite is used to eliminate the need for atomic clock accuracy in the user's receiver, greatly reducing size and cost - one millisecond of error would translate to almost 200 miles of positional error. This is done by using four pseudo-ranges: ranges offset by an unknown (but consistent) error in the user's clock, then and applying simple geometry to eliminate the error from the pseudo-ranges.

The actual ranging information is obtained from the transit time of synchronized RF signals emitted by GPS satellites. Each satellite transmits two carrier frequencies: L1 band at 1,575.42 MHz and L2 band at 1,227.60 MHz. Both carriers are modulated with a 10.23 MHz spread-spectrum code known as the P-code (or Y-code when encrypted using an anti-spoofing A/S technique). P-code has an accuracy of better than 10 m (exact accuracy is not disclosed) and is reserved for military users. In addition, a separate 1.023 MHz modulation known as the C/A code

	Digital Logic	Analog Circuits	Mixed-Signal	Low-Noise Amplifiers	Direct Conversion Transceiver	High-Quality Passives and Filters	Complex RF Switches	Power Amplifiers	Monolithic RF SOC
SOS CMOS	✓✓	✓	✓	✓	✓	BEST	BEST	✓	BEST
Bulk CMOS	BEST	✓	✓	✓	✓	✗	✗	✗	✗
Si Bipolar	✗	BEST	✗	✓	✗	✗	✗	✓	✗
SOI CMOS	✓✓	✓	✓	✓	✓	✗	✓	✗	✗
BICMOS	✓	✓✓	BEST	✓	✓✓	✗	✗	✗	✗
SiGe BICMOS	✓	✓✓	✓✓	✓✓	BEST	✗	✗	✓	✗
III-V FET	✗	✗	✗	BEST	✗	✓	✓✓	✓✓	✗
III-V Bipolar	✗	✗	✗	✓	✗	✓	✗	BEST	✗

RF SoC integration requires ✓ or better. ✗ means the technology cannot integrate the function

Table 2. Comparison of RF System-on-Chip Integration Capability for Semiconductor Processes

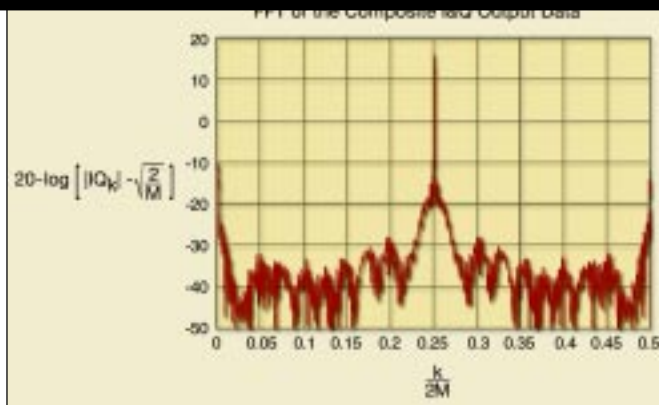

Figure 5. Chip Die Microphotograph of Integrated Anti-Jam Dual Band GPS Receiver

(coarse/acquisition) is applied to the 1,575.42 MHz carrier only. This code is intended for commercial users and allows better than 100 m position accuracy. As a security measure, the C/A code accuracy may be degraded using the S/A (selected availability) feature, which may be applied in times of conflict to deny tactical use of accurate GPS by an enemy.

Both the P and C/A codes are modulated onto the carrier using a spread-spectrum pseudo-noise (PN) sequence. Each satellite is identified by its own unique PN sequence, which is Modulo-2 added to a 50 bps navigation signal (incorporating information about ephemeris data, an almanac, satellite health, ionospheric data, and timing). The C/A code repeats every 1 ms, while the P(Y) code repeats every seven days. The C/A code can be used to quickly acquire the satellite before switching to the P(Y) code.

As well as choice of P or C/A code, actual accuracy of the GPS signal depends on many other factors, such as ionospheric and tropospheric effects, multipath, ephemeris errors and geometric dilution of precision (GDOP). Various techniques have evolved to overcome these problems, including multichannel and dual-band receivers, differential GPS and carrier phase techniques.

Table 1 shows the specified terrestrial GPS signal levels in normal operation. Depending on the implemented bandwidth, the thermal noise floor (kTB) ranges between -114 and -100 dBm, well above the received signal. The significant processing gain possible in the spread spectrum signal allows a positive signal-to-noise ratio to be realized from a signal 30 dB below the noise floor.

GPS applications have grown steadily since the deployment of the constellation. They now take the form of car guidance and map systems, hand-held GPS receivers for hiking and exploring, receivers attached to the body for tracking of running and bicycling training routes and statistics, as well as aviation and nautical use. In fact, GPS is the primary navigation tool for sailors. The integration and subsequent low cost of commercial chipsets have made this possible. For this

growth to continue, a significant reduction in baseline cost is assumed.

Several manufacturers have produced GPS chip sets that result in one-, two-, or three-chip solutions. However, these are for the low-cost commercial market where jamming immunity is not a concern. In general, the higher the perfor-

mance, the lower the integration; dual-band anti-jam GPS receivers have been primarily discrete implementations. Furthermore, none of the commercial chipsets are suitable for radiation environments required by spacecraft.

The migration toward high levels of integration for mass-market products has been well proven in computing and digital signal processing functions, but similar integration for RF and IF functions have not previously been possible, primarily because of isolation and power consumption issues associated with mainstream IC technologies.

BiCMOS processes offer integration but suffer from limited substrate isolation. All-CMOS implementations are possible, but suffer a similar fate. For GaAs, the depletion-mode process used for RF devices is not suitable for low-power digital logic necessary for phase-locked loops (PLLs), RF switch logic and base band functions such as analog-to-digital and digital-to-analog circuitry and processors. Also, cost and manufacturability for GaAs have never matched the levels of Si CMOS. The core of the chipset will always be CMOS.

These basic observations lead to a simple question: CMOS has the lowest manufacturing cost, so how can the parasitics in the substrate be overcome, allowing this technology to be used for high-frequency (RF) integration? This is not a new concept, but a cost-effective implementation has not been achieved until recently. CMOS is only produced using silicon, so silicon-on-insulator (SOI) is an obvious candidate to consider. Four types of SOI are available: SIMOX, bonded wafers, silicon-on-sapphire (SOS), and ultra-thin silicon (UTSi).

SIMOX consists of a thin silicon layer on top of a thin layer of silicon dioxide layer, all prepared by high dose oxygen ion implantation and high temperature annealing of a standard Si wafer. Bonded wafers, often called BESOI, consist of a thin silicon layer on a thicker silicon dioxide layer, produced by bonding two oxide coated wafers together, then grinding and etching one of the wafers until the desired Si film thickness is achieved.

While these SOI technologies have advantages for digital applications, they still present a conductive, dispersive substrate (Si) to any RF elements fabricated into the upper Si layer. Hence, RF parasitics are not significantly improved and complete isolation is not provided.

SOS has a reputation for poor manufacturability, although it provides excellent substrate isolation characteristic. The fundamental problem with traditional SOS is a high-defect density in the silicon layer due to differences in the crystal lattice structures for silicon and sapphire. These defects result in low yield and high processing costs. In addition, the poor yield limits SOS to small-scale integration (SSI) only.

UTSi technology has its roots in SOS. However over the past decade Peregrine Semiconductor has reinvented the SOS process at its fabrication facility in Sydney, Australia. Today, Peregrine has economically applied this technology to the commercial wireless business and enabled second source manufacturing partners. The motivation for doing this is that the insulating sapphire substrate provides an ideal platform to co-integrate both digital and high-frequency RF circuits without interference and cross-talk. The ability to achieve high levels of integration reduces size, cost and power consumption, crucial in consumer mobile communications, as well as space products. Peregrine has perfected the UTSi process and is now in high-volume commercial production, achieving yield and cost levels similar to those in conventional CMOS processing. SOS and certainly UTSi have naturally radiation-hardened properties, making UTSi a suitable technology for integrating GPS receivers for not only military, but also space applications.

UTSi offers several distinct advantages:

- Fully insulating substrate offers unlimited integration potential.
- Integration potential is especially true when flip-chip assembly technology is used to remove the effects of the bond wires.
- Sapphire (Al_2O_3) is essentially organized Alumina, a common microwave substrate chosen for its low loss properties.
- The properties of Sapphire allow the creation of high-quality passives, most notably inductors.
 - No latch-up concerns.
 - Lower capacitance enables higher speed at lower power.
 - Higher speed for a given device geometry offers flexibility in supply voltages.

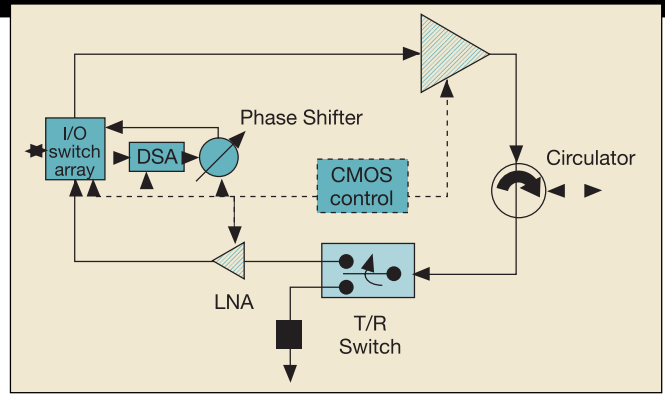

Figure 7. Phased Array Antenna Transmit/Receive T/R Control Block Diagram

- Operation away from the cutting edge of process technology, but with high ft and fmax results in lower manufacturing costs without sacrificing performance.

- Ultra thin silicon layer creates fully depleted devices.

- Nearly ideal 3 terminal MOS device.

- High linearity.

- Makes excellent RF switches and mixers.

- Excellent low voltage performance.

- Radiation immunity.

- Simplified version of standard CMOS processing for reduced cost.

- See figure 3 for device cross-sections.

- No well or isolation mask steps required.

Under a Small Business Innovative Research (SBIR) program, Peregrine has developed a fully integrated anti-jam dual-band GPS receiver, as shown in Figure 4 (block diagram) and Figure 5 (chip die microphotograph). Designed in the 0.5 μm UTSi process, this product integrates complete dual-band, anti-jam GPS receivers from a common antenna input through the digital baseband output, with all elements integrated into a single chip (other than 12 decoupling capacitors and 4 filters). Two full receivers on a chip, it integrates the LNA, mixer, digital step attenuators in a completely self-contained digital gain control loop, the VCOs and PLLs, regulators, FIR filtering and processing, a custom interface, and matching networks and passive devices. The original board-level solution contained 19 ICs (RFICs and a PLD), almost 200 passive devices and 30 square centimeters of board space. The Peregrine product based on this device contains a single IC, a dozen passives and less than 8 square centimeters of board space, and the power consumption was reduced by more than a factor of two.

Features of the anti-jam dual band GPS receiver:

- Integration of two receivers from antenna in through processed bits out.

- Simultaneous operation of two complete receivers including VCOs, PLLs, A/Ds and digital processing without mutual interference.

- Low voltage/low power.

- Improved performance.
- Ease of implementation – reduced cycle time.
- Both receivers in a monolithic solution – good amplitude and phase matching between receivers.
- Packaged in an 11x11 mm BGA package.
- Use of digital step attenuators for increased linearity throughout entire gain control range.
- Results in accurate signal-level reporting without calibration tables.
- Allows the AGC loop bandwidth to be controlled digitally (loop is contained on-chip).
- Removes extra digital/analog conversions in a mixed digital/analog loop.
- Gain control circuits optimized for low phase distortion.
- Custom integer and fractional-N synthesizers with high comparison frequency.
- Minimizes contamination of IF signal.
- Improved close-in oscillator sideband noise performance.
- Two fully integrated oscillators.
- Two internal A/D converters, FIR filters, plus support of external A/D converters.
- Three separate regulators for supply isolation.
- Power-down capability.
- Reference oscillator (with external crystal).
- Internal reference doubler.

Due to the insulating substrate, a high signal-to-noise and distortion ratio can be achieved with both receivers running simultaneously, as shown in Figure 6. This plot is constructed by post-processing the I and Q digital outputs to phase shift the Q signal, FFT the two datastreams, then summing them together. Note that the spectrum is free of spurious signals over the Nyquist bandwidth.

A radiation-hardened, single-chip GPS receiver would have applications to commercial satellites, where cost and weight are crucial. This development could lead to a new class of micro or pico satellites. The use of a single-chip, radiation-hardened GPS receiver would enable substantially improved satellite and strategic weapons systems, with reduced size, weight, cost and volume as the major benefits. However, other applications become possible, including attitude control for large satellites and micro or pico satellites for which navigation subsystems are a major issue. Peregrine is developing a low-cost, single-chip, miniature GPS receiver suitable for space and radiation environments.

For future process development, Peregrine has a technology road map that includes migration to 0.25 μm gate lengths. These developments will further improve speed and power ratio of digital devices and also enhance per-

formance of RF active devices. It is also possible to integrate larger arrays of receivers on a single chip. Consequently, the company is developing multichannel GPS receivers for additional military and space applications. It is also developing phased array antenna element control circuits, as shown in the block diagram of Figure 7. The shaded items are areas for future integration.

By combining the anti-jam dual band GPS receivers with the phased array antenna element control circuits, a highly integrated anti-jam GPS receiver with antenna steering processing could be constructed in a monolithic solution. These ideas can be extended not only to military and space markets, but also to industrial applications. The industrial applications would be characterized by non-hostile environments, where susceptibility to an incidental jammer cannot be tolerated. As industrial GPS users such as railway, airline, and trucking industries find themselves reliant on GPS receivers, inherent anti-jam capability will grow in importance. Already these industries are looking to systems like Loran-C as backups to GPS. Improved receiver technology will certainly be required.

Highly integrated low-cost, anti-jam GPS receivers are required for military systems and will find their way into industrial use as well. The integration will enable new markets and opportunities. GPS receivers are making the transition from luxury to necessity. As this happens, we will find an increasing reliance on the technology.

References

1. "Global Positioning System: Theory and Applications, Vol. I." Editors, Bradford W. Parkinson and James J. Spilker Jr., Progress in Astronautics and Aeronautics, 163, 1996. ISBN 1-56347-106-X.
2. "Understanding GPS Principles and Applications", Editor, Elliot D. Kaplan, Artech House, 1996. ISBN 0-89006-793-7.
3. PBS Online - PBS Frontline Program "The Gulf War" January 9, 1996
www.pbs.org/wgbh/pages/frontline/gulf/

About the author

Dan Nobbe is vice president of engineering. He joined Peregrine in 2000 and served as director of design and site manager prior to his current role. Before joining Peregrine, Nobbe designed RF ICs for cellular handsets and product design for cellular handsets, cellular infrastructure, and two-way radios. His radio and IC design career spans 14 years. He holds a Bachelor's degree in electrical engineering from the University of Missouri-Rolla and a Master's Degree from the University of Texas at Arlington. He has three patents awarded and three pending.