

Product Description

Peregrine's PE97042 is a high-performance integer-N PLL capable of frequency synthesis up to 3500 MHz. The device is designed for superior phase noise performance while providing an order of magnitude reduction in current consumption, when compared with existing commercial space PLLs.

The PE97042 features a $\div 10/11$ dual modulus prescaler, counters, and a phase comparator as shown in Figure 1. Counter values are programmable through a serial interface, and can also be directly hard wired.

The PE97042 is optimized for commercial space applications. Single Event Latch up (SEL) is physically impossible and Single Event Upset (SEU) is better than 10^{-9} errors per bit / day. It is manufactured on Peregrine's UltraCMOS™ process, a patented variation of silicon-on-insulator (SOI) technology on a sapphire substrate, offering excellent RF performance and intrinsic radiation tolerance.

Features

- Low Power: 45 mA Typical
- 3500 MHz operation
- $\div 10/11$ dual modulus prescaler
- Phase detector output
- Serial interface or hardwired programmable
- Ultra-Low Phase Noise: -216 dBc/Hz
- SEU < 10^{-9} errors / bit-day
- 100 Krad (Si) total dose
- Easily modified to be pin compatible with the PE9704, packaged in a 44-lead CQFJ (reference application note AN23 at www.psemi.com)

Figure 1. Block Diagram

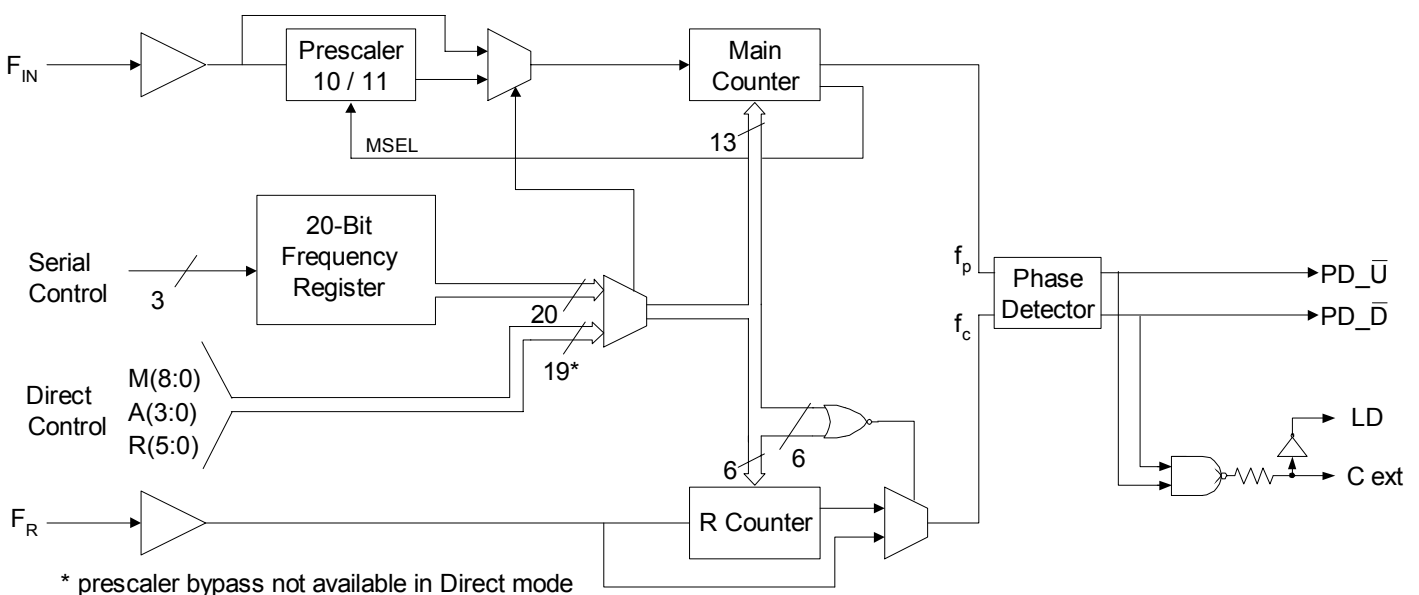
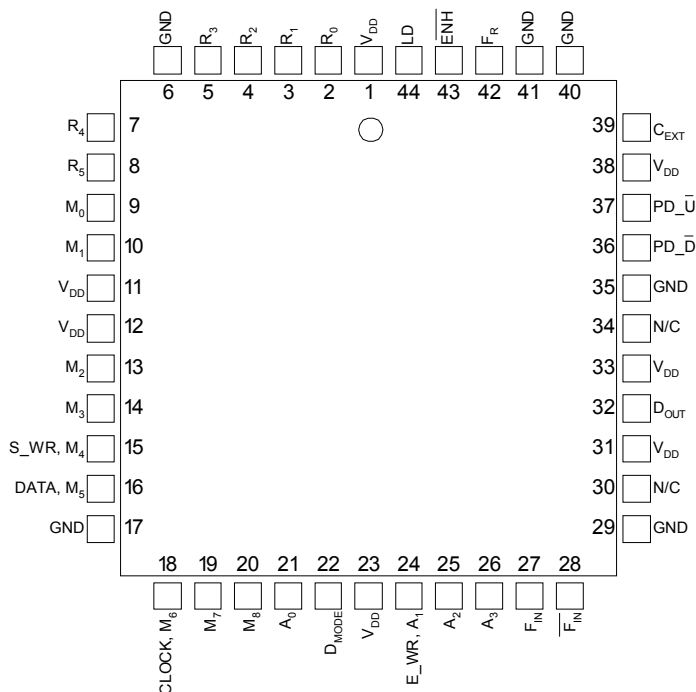
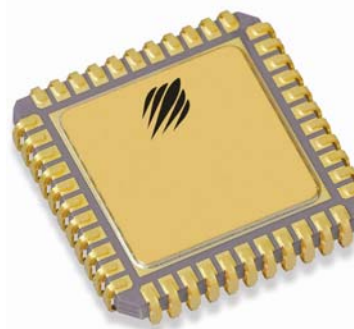

Figure 2. Pin Configurations (Top View)

Figure 3. Package Type
44-lead CQFJ

Table 1. Pin Descriptions

Pin No.	Pin Name	Interface Mode	Type	Description
1	V _{DD}	Both	(Note 1)	Power supply input. Input may range from 2.85 V to 3.45 V. Bypassing recommended.
2	R ₀	Direct	Input	R Counter bit0
3	R ₁	Direct	Input	R Counter bit1
4	R ₂	Direct	Input	R Counter bit2
5	R ₃	Direct	Input	R Counter bit3
6	GND	Both	(Note 1)	Ground
7	R ₄	Direct	Input	R Counter bit4
8	R ₅	Direct	Input	R Counter bit5 (MSB)
9	M ₀	Direct	Input	M Counter bit0
10	M ₁	Direct	Input	M Counter bit1
11	V _{DD}	Both	(Note 1)	Same as pin 1
12	V _{DD}	Both	(Note 1)	Same as pin 1
13	M ₂	Direct	Input	M Counter bit2
14	M ₃	Direct	Input	M Counter bit3
15	S_WR	Serial	Input	Frequency register load enable input. Buffered data is transferred to the frequency register on S_WR rising edge.
	M ₄	Direct	Input	M Counter bit4
16	DATA	Serial	Input	Binary serial data input. Data is entered LSB first, and is clocked serially into the 20-bit frequency control register (E_WR "low") or the 8-bit enhancement register (E_WR "high") on the rising edge of CLOCK.
	M ₅	Direct	Input	M Counter bit5

Table 1. Pin Descriptions (continued)

Pin No.	Pin Name	Interface Mode	Type	Description
17	GND	Both		Ground
18	CLOCK	Serial	Input	Clock input. Data is clocked serially into either the 20-bit primary register (E_WR "low") or the 8-bit enhancement register (E_WR "high") on the rising edge of CLOCK.
	M ₆	Direct	Input	M Counter bit6
19	M ₇	Direct	Input	M Counter bit7
20	M ₈	Direct	Input	M Counter bit8 (MSB)
21	A ₀	Direct	Input	A Counter bit0
22	D _{MODE}	Both	Input	Selects direct interface mode (D _{MODE} =1) or serial interface mode (D _{MODE} =0)
23	V _{DD}	Both	(Note 1)	Same as pin 1
24	E_WR	Serial	Input	Enhancement register write enable. While E_WR is "high", DATA can be serially clocked into the enhancement register on the rising edge of CLOCK.
	A ₁	Direct	Input	A Counter bit1.
25	A ₂	Direct	Input	A Counter bit2
26	A ₃	Direct	Input	A Counter bit3 (MSB)
27	F _{IN}	Both	Input	RF prescaler input from the VCO. 3.5 GHz maximum frequency.
28	F _{IN} [¯]	Both		F _{IN} [¯] pin requires a 22 pF capacitor in series with a 51 ohm resistor to ground
29	GND	Both		Ground.
30	N/C			No connect.
31	V _{DD}	Both	(Note 1)	Same as pin 1
32	D _{OUT}	Serial	Output	Data Out. The Main Counter output, R Counter output, or dual modulus prescaler select (MSEL) can be routed to D _{OUT} through enhancement register programming.
33	V _{DD}	Both	(Note 1)	Same as pin 1
34	N/C			No connect.
35	GND	Both		Ground.
36	PD _¯	Both	Output	PD _¯ pulses down when f _p leads f _c .
37	PD _¯	Both		PD _¯ pulses down when f _c leads f _p .
38	V _{DD}	Both	(Note 1)	Same as pin 1
39	C _{EXT}	Both	Output	Logical "NAND" of PD _¯ and PD _¯ , passed through an on-chip, 2 kΩ series resistor. Connecting C _{EXT} to an external capacitor will low pass filter the input to the inverting amplifier used for driving LD.
40	GND	Both		Ground
41	GND	Both		Ground
42	F _R	Both	Input	Reference frequency input
43	ENH	Both	Output, OD	Enhancement mode. When asserted low ("0"), enhancement register bits are functional.
44	LD	Serial	Output	Lock detect output, the open-drain logical inversion of C _{EXT} . When the loop is locked, LD is high impedance; otherwise LD is a logic low ("0").

Note 1: V_{DD} pins 1, 11, 12, 23, 31, 33, 35, and 38 are connected by diodes and must be supplied with the same positive voltage level.

Note 2: All digital input pins have 70 kΩ pull-up resistors to V_{DD}.

Table 2. Absolute Maximum Ratings

Symbol	Parameter/Conditions	Min	Max	Units
V_{DD}	Supply voltage	-0.3	4.0	V
V_I	Voltage on any input	-0.3	$V_{DD} + 0.3$	V
I_I	DC into any input	-10	+10	mA
I_O	DC into any output	-10	+10	mA
T_{stg}	Storage temperature range	-65	150	°C

Table 3. Operating Ratings

Symbol	Parameter/Conditions	Min	Max	Units
V_{DD}	Supply voltage	2.85	3.45	V
T_A	Operating ambient temperature range	-40	85	°C

Exceeding absolute maximum ratings may cause permanent damage. Operation should be restricted to the limits in the Operating Ranges table. Operation between operating range maximum and absolute maximum for extended periods may reduce reliability.

Table 4. ESD Ratings

Symbol	Parameter/Conditions	Level	Units
V_{ESD}	ESD voltage (Human Body Model) – Note 1	1000	V

Note 1: Periodically sampled, not 100% tested. Tested per MIL-STD-883, M3015 C2

Electrostatic Discharge (ESD) Precautions

When handling this UltraCMOS™ device, observe the same precautions that you would use with other ESD-sensitive devices. Although this device contains circuitry to protect it from damage due to ESD, precautions should be taken to avoid exceeding the specified rating.

Latch-Up Avoidance

Unlike conventional CMOS devices, UltraCMOS™ devices are immune to latch-up.

Table 5. DC Characteristics: $V_{DD} = 3.3\text{ V}$, $-40^\circ\text{ C} < T_A < 85^\circ\text{ C}$, unless otherwise specified

Symbol	Parameter	Conditions	Min	Typ	Max	Units
I_{DD}	Operational supply current;	$V_{DD} = 3.30\text{ V}$				mA
	Prescaler disabled					
	Prescaler enabled					mA
Digital Inputs: All except F_R, F_{IN} (all digital inputs have 70 kΩ pull-up resistors)						
V_{IH}	High level input voltage	$V_{DD} = 2.85\text{ to }3.45\text{ V}$	$0.7 \times V_{DD}$			V
V_{IL}	Low level input voltage	$V_{DD} = 2.85\text{ to }3.45\text{ V}$			$0.3 \times V_{DD}$	V
I_{IH}	High level input current	$V_{IH} = V_{DD} = 3.45\text{ V}$			70	μA
I_{IL}	Low level input current	$V_{IL} = 0, V_{DD} = 3.45\text{ V}$	-1			μA
Reference Divider input: F_R						
I_{IHR}	High level input current	$V_{IH} = V_{DD} = 3.45\text{ V}$			100	μA
I_{ILR}	Low level input current	$V_{IL} = 0, V_{DD} = 3.45\text{ V}$	-100			μA
Counter and phase detector outputs: f_c, f_p						
V_{OLD}	Output voltage LOW	$I_{out} = 6\text{ mA}$			0.4	V
V_{OHD}	Output voltage HIGH	$I_{out} = -3\text{ mA}$	$V_{DD} - 0.4$			V
Lock detect outputs: C_{EXT}, LD						
V_{OLC}	Output voltage LOW, C_{EXT}	$I_{out} = 100\text{ μA}$			0.4	V
V_{OHC}	Output voltage HIGH, C_{EXT}	$I_{out} = -100\text{ μA}$	$V_{DD} - 0.4$			V
V_{OLLD}	Output voltage LOW, LD	$I_{out} = 1\text{ mA}$			0.4	V

Table 6. AC Characteristics: $V_{DD} = 3.3\text{ V}$, $-40^\circ\text{ C} < T_A < 85^\circ\text{ C}$, unless otherwise specified

Symbol	Parameter	Conditions	Min	Typical	Max	Units
Control Interface and Latches (see Figures 1 and 9)						
f_{CLK}	CLOCK Serial data clock frequency	(Note 1)			10	MHz
t_{CLKH}	CLOCK Serial clock HIGH time		30			ns
t_{CLKL}	CLOCK Serial clock LOW time		30			ns
t_{DSU}	DATA set-up time after CLOCK rising edge		10			ns
t_{DHLD}	DATA hold time after CLOCK rising edge		10			ns
t_{PW}	S_WR pulse width		30			ns
t_{CWR}	CLOCK rising edge to S_WR rising edge.		30			ns
t_{CE}	CLOCK falling edge to E_WR transition		30			ns
t_{WRC}	S_WR falling edge to CLOCK rising edge.		30			ns
t_{EC}	E_WR transition to CLOCK rising edge		30			ns
t_{MDO}	MSEL data out delay after F_{IN} rising edge	$C_L = 12\text{ pf}$			8	ns
Main Divider (Including Prescaler) (Note 4)						
P_{Fin}	Input level range	External AC coupling $275\text{ MHz} \leq \text{Freq} \leq 3200\text{MHz}$	-5		5	dBm
		External AC coupling $3.2\text{ GHz} < \text{Freq} \leq 3.5\text{ GHz}$ $3.15\text{ V} \leq V_{DD} \leq 3.45\text{ V}$	0		5	dBm
Main Divider (Prescaler Bypassed) (Note 4)						
F_{IN}	Operating frequency		50		300	MHz
P_{Fin}	Input level range	External AC coupling	-5		5	dBm
Reference Divider						
F_R	Operating frequency	(Note 3)			100	MHz
P_{Fr}	Reference input power (Note 2)	Single-ended input	-2		10	dBm
Phase Detector						
f_c	Comparison frequency	(Note 3)			50	MHz
SSB Phase Noise ($F_{in} = 1.9\text{ GHz}$, $f_r = 20\text{ MHz}$, $f_c = 20\text{ MHz}$, $LBW = 50\text{ kHz}$, $V_{DD} = 3.3\text{ V}$, $\text{Temp} = 25^\circ\text{ C}$) (Note 4)						
Φ_N	Phase Noise	100 Hz Offset		-89		dBc/Hz
Φ_N	Phase Noise	1 kHz Offset		-95		dBc/Hz
Φ_N	Phase Noise	10 kHz Offset		-102		dBc/Hz
SSB Phase Noise ($F_{in} = 1.9\text{ GHz}$, $f_r = 20\text{ MHz}$, $f_c = 20\text{ MHz}$, $LBW = 50\text{ kHz}$, $V_{DD} = 3.0\text{ V}$, $\text{Temp} = 25^\circ\text{ C}$) (Note 4)						
Φ_N	Phase Noise	100 Hz Offset		-87		dBc/Hz
Φ_N	Phase Noise	1 kHz Offset		-94		dBc/Hz
Φ_N	Phase Noise	10 kHz Offset		-101		dBc/Hz

Note 1: f_{clk} is verified during the functional pattern test. Serial programming sections of the functional pattern are clocked at 10 MHz to verify f_{clk} specification.

Note 2: CMOS logic levels can be used to drive reference input if DC coupled. For Sin wave inputs, amplitude needs to be a minimum of 0.5Vp-p.

Note 3: Parameter is guaranteed through characterization only and is not tested.

Note 4: Parameters below are not tested for die sales. These parameters are verified during the element evaluation.

Figure 4. RF Sensitivity versus Frequency (typical device at temperature = 25° C)

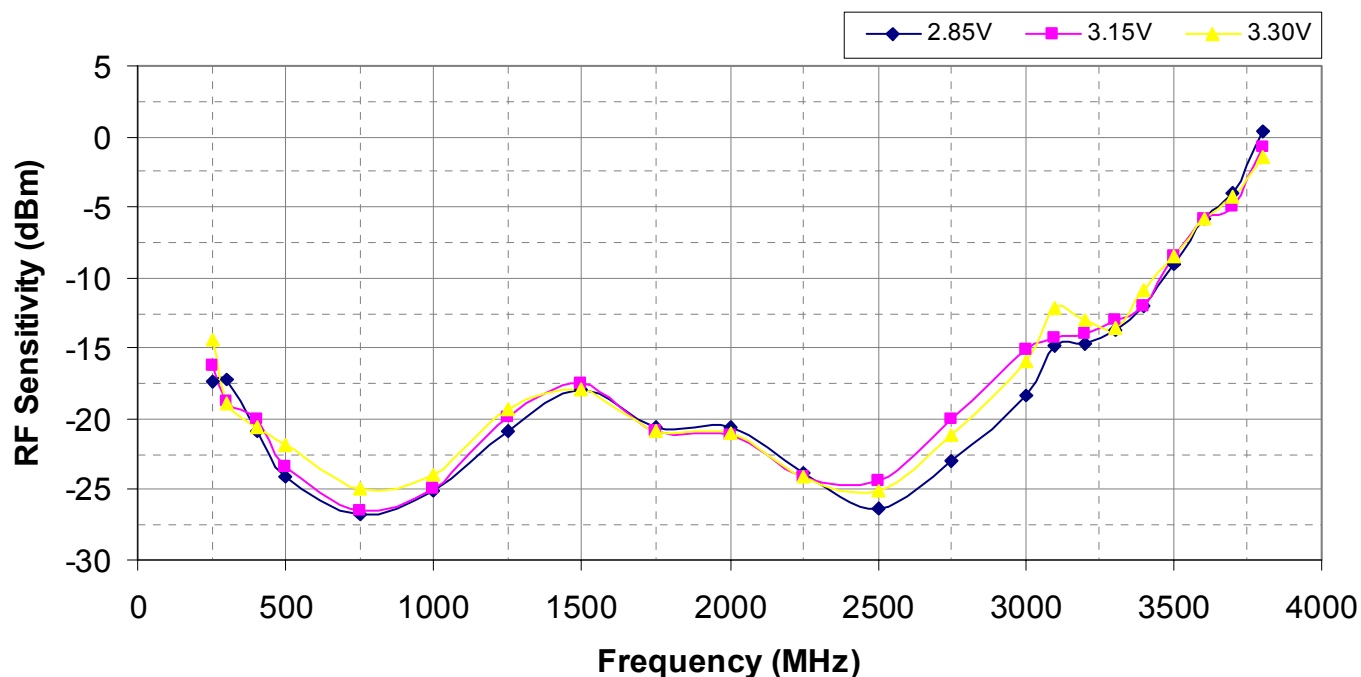

Figure 5. Typical Phase Noise for PE97042, VDD = 3.3 V, Temp = 25 C, Fvco = 1.92 GHz, Fcomp = 20 MHz, Loop Bandwidth = 50 kHz

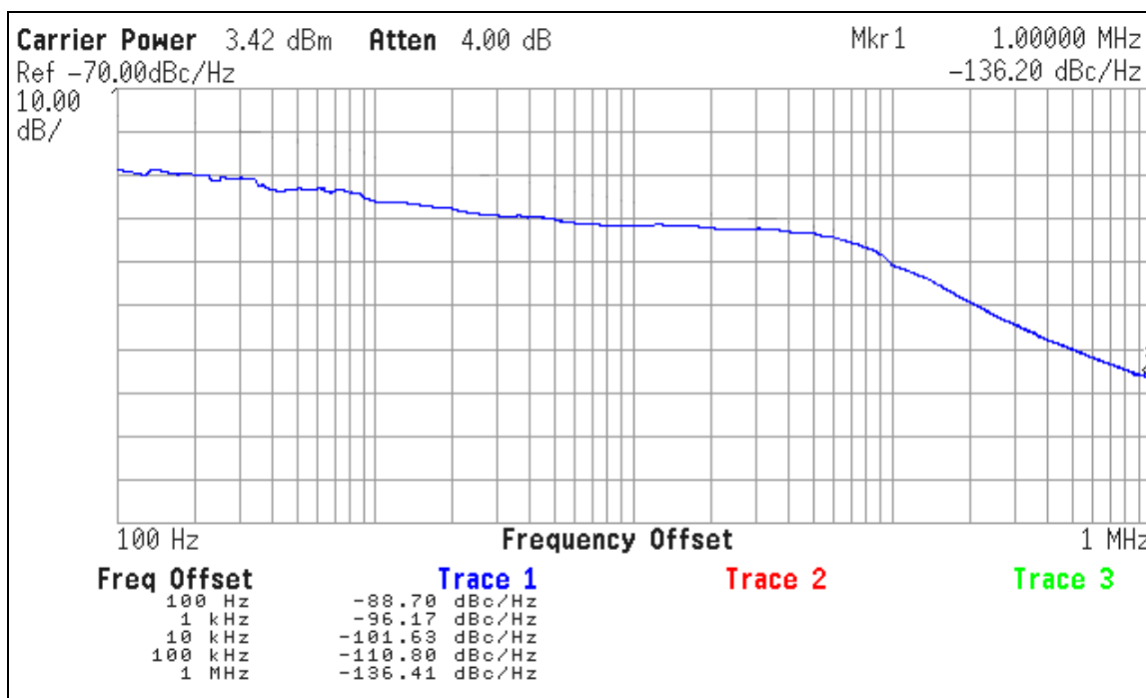

Figure 6. Equivalent Input Diagram: Reference Input

Peregrine Specification 71/0032

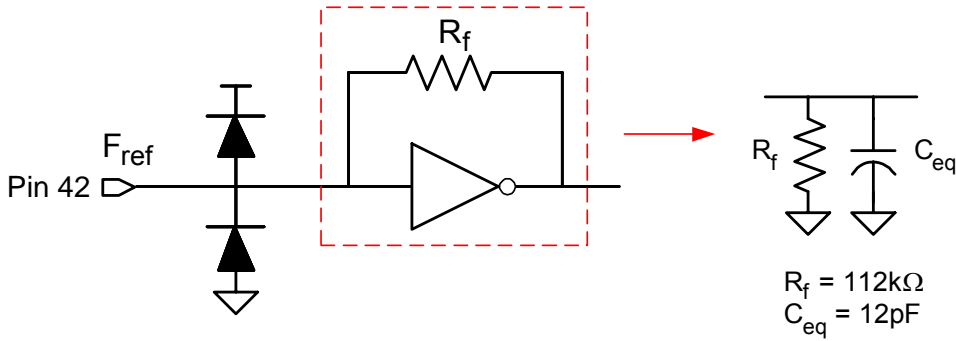

Figure 7. Equivalent Input Diagram: Main Input

Peregrine Specification 71/0033

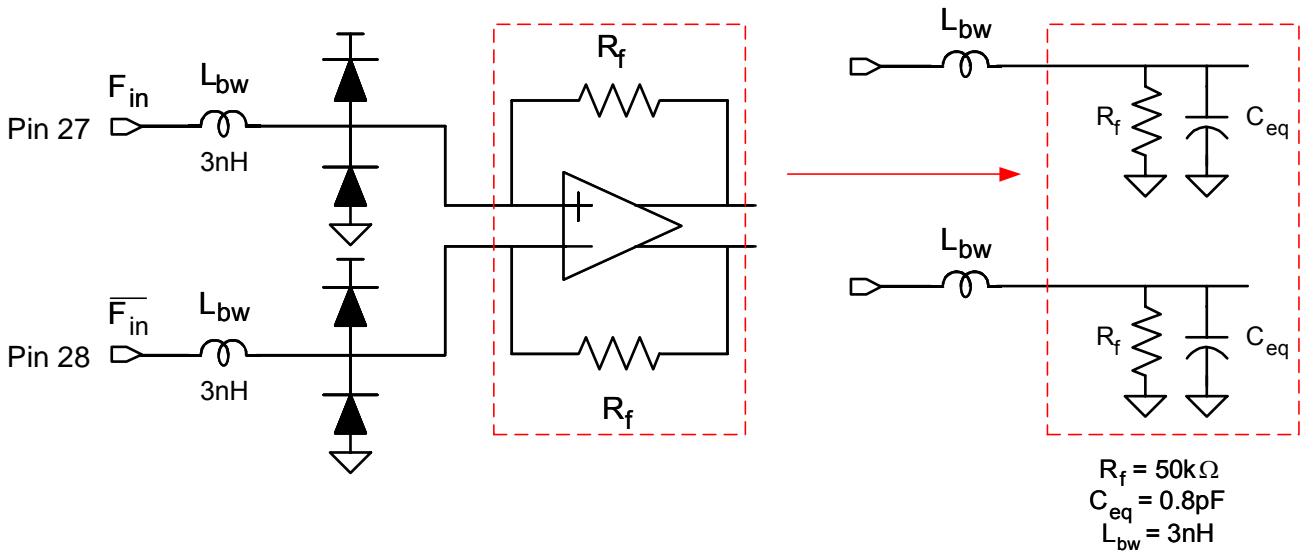
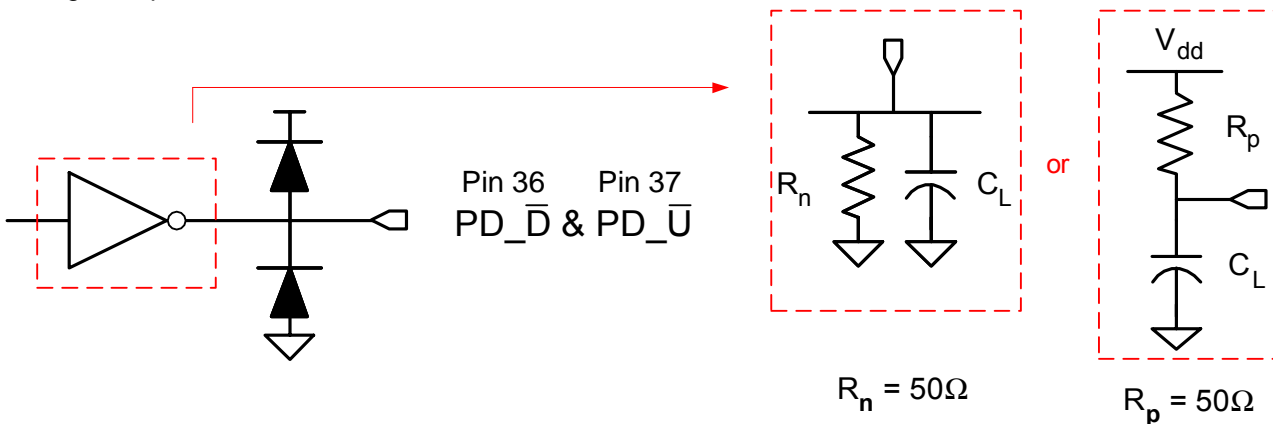

Figure 8. Equivalent Output Diagram: PD_D & PD_U Outputs

Peregrine Specification 71/0034



Functional Description

The PE97042 consists of a prescaler, counters, a phase detector, and control logic. The dual modulus prescaler divides the VCO frequency by either 10 or 11, depending on the value of the modulus select. Counters “R” and “M” divide the reference and prescaler output, respectively, by integer values stored in a 20-bit register. An additional counter (“A”) is used in the modulus select logic. The phase-frequency detector generates up and down frequency control signals. The control logic includes a selectable chip interface. Data can be written via a serial bus or hardwired directly to the pins. There are also various operational and test modes and a lock detect output.

Main Counter Chain

Normal Operating Mode

Setting the PB control bit “low” enables the ÷10/11 prescaler. The main counter chain then divides the RF input frequency (F_{IN}) by an integer derived from the values in the “M” and “A” counters.

In this mode, the output from the main counter chain (f_p) is related to the VCO frequency (F_{IN}) by the following equation:

$$f_p = F_{IN} / [10 \times (M + 1) + A] \quad (1)$$

where $A \leq M + 1$, $1 \leq M \leq 511$

When the loop is locked, F_{IN} is related to the reference frequency (F_R) by the following equation:

$$F_{IN} = [10 \times (M + 1) + A] \times (F_R / (R+1)) \quad (2)$$

where $A \leq M + 1$, $1 \leq M \leq 511$

A consequence of the upper limit on A is that F_{IN} must be greater than or equal to $90 \times (F_R / (R+1))$ to obtain contiguous channels. The A counter can accept values as high as 15, but in typical operation it will cycle from 0 to 9 between increments in M.

Programming the M counter with the minimum allowed value of “1” will result in a minimum M counter divide ratio of “2”.

Prescaler Bypass Mode

Setting the enhancement register bit PB “high” allows F_{IN} to bypass the ÷10/11 prescaler. In this mode, the prescaler and A counter are powered down, and the input VCO frequency is divided by the M counter directly. This mode is only available when using the serial port to set the frequency control bits. The following equation relates F_{IN} to the reference frequency F_R :

$$F_{IN} = (M + 1) \times (F_R / (R+1)) \quad (3)$$

where $1 \leq M \leq 511$

Reference Counter

The reference counter chain divides the reference frequency F_R down to the phase detector comparison frequency f_c .

The output frequency of the 6-bit R Counter is related to the reference frequency by the following equation:

$$f_c = F_R / (R + 1) \quad (4)$$

where $0 \leq R \leq 63$

Note that programming R with “0” will pass the reference frequency (F_R) directly to the phase detector.

Register Programming

Serial Interface Mode

Serial Interface Mode is selected by setting the D_{MODE} input “low”.

While the E_WR input is “low”, serial data (DATA input), B_0 to B_{19} , is clocked into a buffer register on the rising edge of CLOCK, LSB (B_0) first. The contents from this buffer register are transferred into the frequency control register on the rising edge of S_WR according to the timing diagram shown in *Figure 9*. This data controls the counters as shown in *Table 7*.

While the E_WR input is “high”, serial data (DATA input), B_0 to B_7 , is clocked into a buffer register on the rising edge of CLOCK, LSB (B_0) first. The contents from this buffer register are transferred into the enhancement register on the falling edge of E_WR according to the timing diagram shown

in *Figure 9*. After the falling edge of E_WR , the data provides control bits as shown in *Table 8*. These bits are active when the ENH input is “low”.

Direct Interface Mode

Direct Interface Mode is selected by setting the D_{MODE} input “high”. In this mode, the counter values are set directly at external pins as shown in *Table 7* and *Figure 2*. All frequency control register bits are addressable except PB (it is not possible to bypass the $\div 10/11$ dual modulus prescaler in Direct Mode).

Table 7. Frequency Register Programming

Interface Mode	ENH	D_{MODE}	R_5	R_4	M_8	M_7	X	M_6	M_5	M_4	M_3	M_2	M_1	M_0	R_3	R_2	R_1	R_0	A_3	A_2	A_1	A_0
Serial*	1	0	B_0	B_1	B_2	B_3	B_4	B_5	B_6	B_7	B_8	B_9	B_{10}	B_{11}	B_{12}	B_{13}	B_{14}	B_{15}	B_{16}	B_{17}	B_{18}	B_{19}
Direct	1	1	R_5	R_4	M_8	M_7	0	M_6	M_5	M_4	M_3	M_2	M_1	M_0	R_3	R_2	R_1	R_0	A_3	A_2	A_1	A_0

* Data is clocked serially on CLOCK rising edge while E_WR is “low” and transferred to frequency register on S_WR rising edge.

↑
MSB (first in)

(last in) LSB ↑

Table 8. Enhancement Register Programming

Interface Mode	ENH	D_{MODE}	Reserved*	Reserved*	fp output	Power down	Counter load	MSEL output	fc output	PB
Serial**	0	X	B_0	B_1	B_2	B_3	B_4	B_5	B_6	B_7

* Program to 0

* Data is clocked serially on CLOCK rising edge while E_WR is “low” and transferred to frequency register on S_WR rising edge.

↑
MSB (first in)

(last in) LSB ↑

Figure 9. Serial Interface Mode Timing Diagram

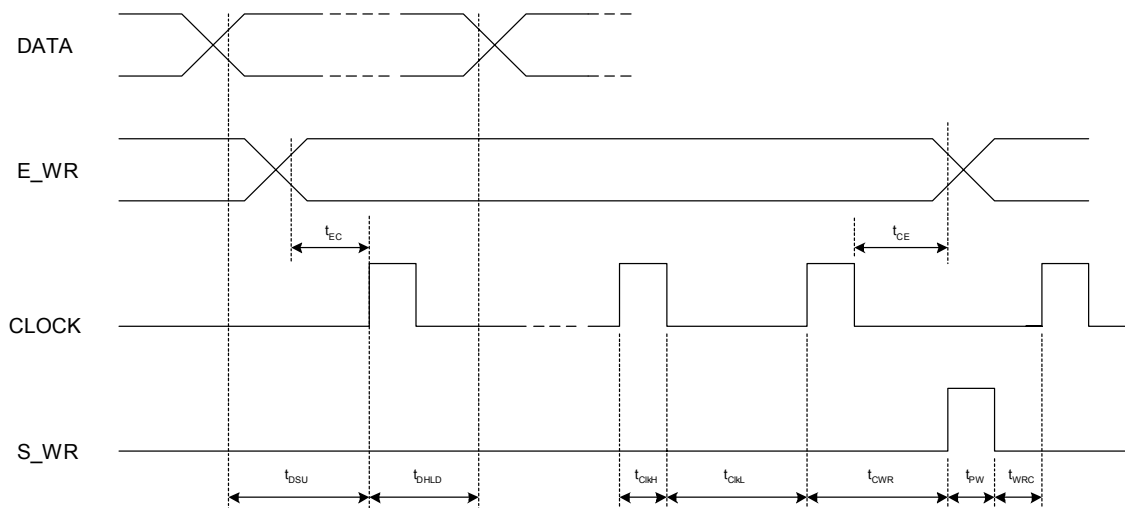

Enhancement Register

The functions of the enhancement register bits are shown below. All bits are active high. Operation is undefined if more than one output is sent to D_{OUT}.

Table 9. Enhancement Register Bit Functionality

Bit Function	Description	
Bit 0	Reserved**	
Bit 1	Reserved**	
Bit 2	f _p output	Drives the M counter output onto the D _{OUT} output.
Bit 3	Power down	Power down of all functions except programming interface.
Bit 4	Counter load	Immediate and continuous load of counter programming.
Bit 5	MSEL output	Drives the internal dual modulus prescaler modulus select (MSEL) onto the D _{OUT} output.
Bit 6	f _c output	Drives the R counter output onto the D _{OUT} output
Bit 7	PB	Allows Fin to bypass the 10/11 prescaler

** Program to 0

Phase Detector Outputs

The phase detector is triggered by rising edges from the main counter (f_p) and the reference counter (f_c). It has two outputs, PD_U, and PD_D. If the divided VCO leads the divided reference in phase or frequency (f_p leads f_c), PD_D pulses “low”. If the divided reference leads the divided VCO in phase or frequency (f_c leads f_p), PD_U pulses “low”. The width of either pulse is directly proportional to phase offset between the two input signals, f_p and f_c. The phase detector gain is 430 mV / radian.

PD_U and PD_D are designed to drive an active loop filter which controls the VCO tune voltage. PD_U pulses result in an increase in VCO frequency

and PD_D results in a decrease in VCO frequency.

Software tools for designing the active loop filter can be found at Peregrine’s web site: www.psemi.com

Lock Detect Output

A lock detect signal is provided at pin LD, via the pin C_{EXT} (see Figure 1). C_{EXT} is the logical “NAND” of PD_U and PD_D waveforms, driven through a series 2 kΩ resistor. Connecting C_{EXT} to an external shunt capacitor provides integration of this signal.

The C_{EXT} signal is then sent to the LD pin through an internal inverting comparator with an open drain output. Thus LD is an “AND” function of PD_U and PD_D.

Sales Offices

The Americas

Peregrine Semiconductor Corporation

9380 Carroll Park Drive
San Diego, CA 92121
Tel: 858-731-9400
Fax: 858-731-9499

Europe

Peregrine Semiconductor Europe

Bâtiment Maine
13-15 rue des Quatre Vents
F-92380 Garches, France
Tel: +33-1-4741-9173
Fax : +33-1-4741-9173

High-Reliability and Defense Products

Americas

San Diego, CA, USA
Phone: 858-731-9475
Fax: 848-731-9499

Europe/Asia-Pacific

Parc Cezanne 1
380 Avenue Archimède, Parc de la Duranne
13857 Aix-En-Provence Cedex 3, France
Phone: +33-4-4239-3361
Fax: +33-4-4239-7227

Peregrine Semiconductor, Asia Pacific (APAC)

Shanghai, 200040, P.R. China
Tel: +86-21-5836-8276
Fax: +86-21-5836-7652

Peregrine Semiconductor, Korea

#B-2607, Kolon Tripolis, 210
Geumgok-dong, Bundang-gu, Seongnam-si
Gyeonggi-do, 463-943 South Korea
Tel: +82-31-728-3939
Fax: +82-31-728-3940

Peregrine Semiconductor K.K., Japan

Teikoku Hotel Tower 10B-6
1-1-1 Uchisaiwai-cho, Chiyoda-ku
Tokyo 100-0011 Japan
Tel: +81-3-3502-5211
Fax: +81-3-3502-5213

For a list of representatives in your area, please refer to our
Web site at: www.psemi.com

Data Sheet Identification

Advance Information

The product is in a formative or design stage. The data sheet contains design target specifications for product development. Specifications and features may change in any manner without notice.

Preliminary Specification

The data sheet contains preliminary data. Additional data may be added at a later date. Peregrine reserves the right to change specifications at any time without notice in order to supply the best possible product.

Product Specification

The data sheet contains final data. In the event Peregrine decides to change the specifications, Peregrine will notify customers of the intended changes by issuing a CNF (Customer Notification Form).

The information in this data sheet is believed to be reliable. However, Peregrine assumes no liability for the use of this information. Use shall be entirely at the user's own risk.

No patent rights or licenses to any circuits described in this data sheet are implied or granted to any third party.

Peregrine's products are not designed or intended for use in devices or systems intended for surgical implant, or in other applications intended to support or sustain life, or in any application in which the failure of the Peregrine product could create a situation in which personal injury or death might occur. Peregrine assumes no liability for damages, including consequential or incidental damages, arising out of the use of its products in such applications.

The Peregrine name, logo, and UTSi are registered trademarks and UltraCMOS, HaRP, MultiSwitch and DuNE are trademarks of Peregrine Semiconductor Corp.